

Questionnaire for Price Quotation for a Moveable Trash Rack Cleaner

I. Contact Data

PROJECT NAME
(please reference on all correspondence)

PROJECT SITE
(location and country)

Contact name Company

Address

ZIP code / City Country

Phone Mobile

E-mail Web

Developer Consulting Agency Name of Project Owner

II. Status

Feasibility study Contract pending; construction scheduled for:

Public tender Deadline for submitting an offer:

Construction of a new power plant Modernisation of an existing plant

III. Technical data

A Screen inclination °

B Screen pedestal mm

C Roof projection mm

D Height of roof mm

E Height of apron mm

G Distance to gate mm

H Height of pedestal mm

L Screen length mm

T Water depth min. mm
max. mm

Tension V

Frequency Hz

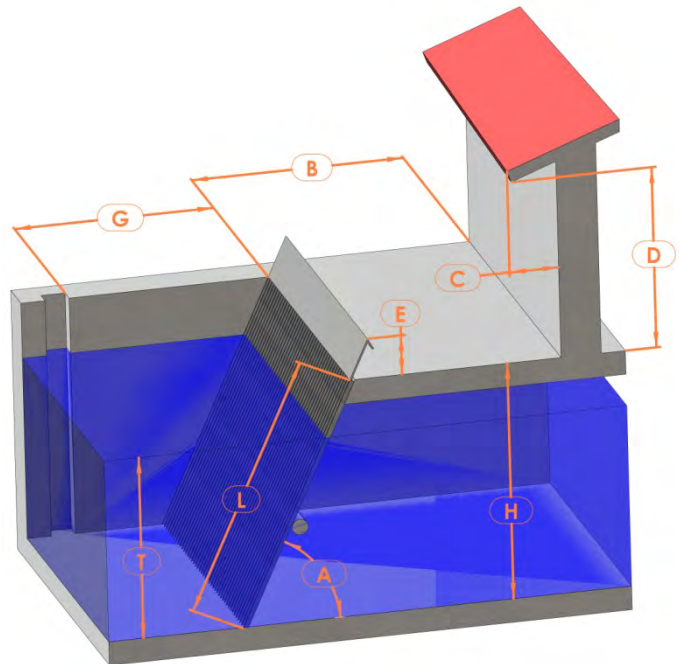

Outside temperature between -10°C and +40°C yes no; temperature from °C to °C

Screening disposal Container with base flap Returnable container
 Conveyor Wash-out channel

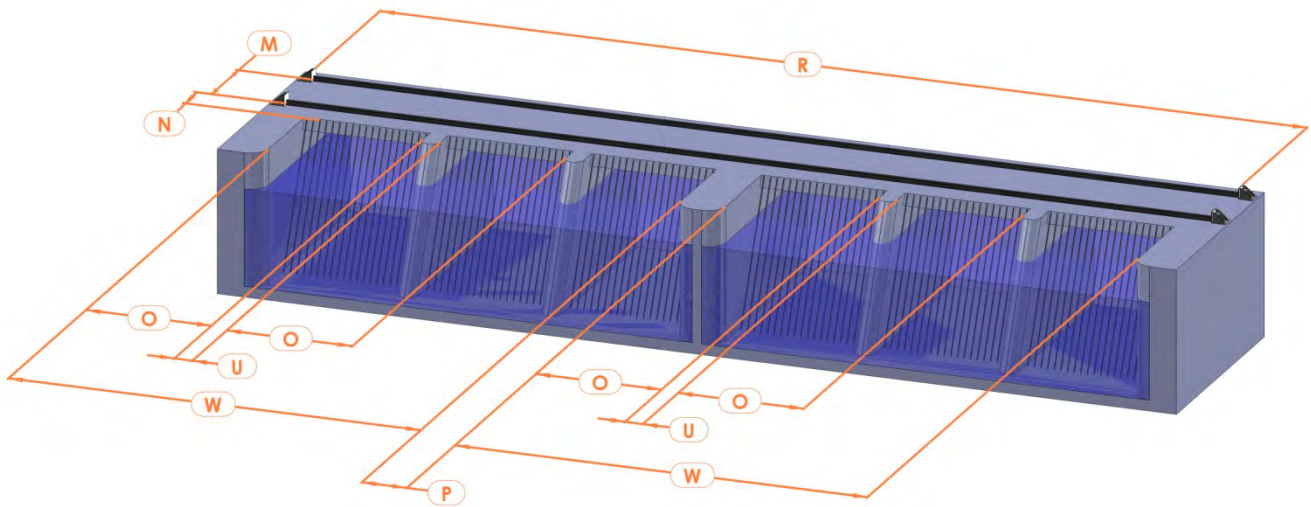

W Inlet width mm

Number of inlets W

O Screen width mm

Number of screens O per inlet W

P Concrete wall width mm
between the individual inlets

U Partition wall width mm
between the individual screens

Spacing of screen bars mm

M Distance of rails mm

N Distance of rail mm
to front edge of screen

R Rail length mm

X Rail width mm

Y Rail height mm

Type of rail

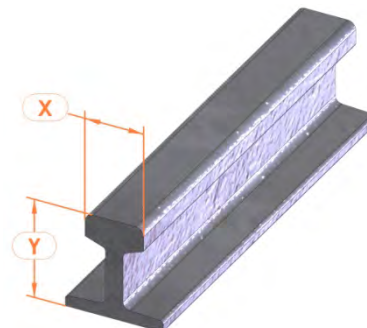

IV. Comments

Date, place

Signature

OSSBERGER GmbH + Co.KG
 Otto-Rieder-Strasse 5-11
 D-91781 Weissenburg
 GERMANY
 +49 (0) 91 41 / 9 77-0
info@ossberger.de
www.ossberger.de

